



# PISO-DA2/DA2U

## User Manual

Version 2.7

Mar. 2012

### Warranty

---

All products manufactured by ICP DAS are warranted against defective materials for a period of one year from the date of delivery to the original purchaser.

### Warning

---

ICP DAS assumes no liability for damages consequent to the use of this product. ICP DAS reserves the right to change this manual at any time without notice. The information furnished by ICP DAS is believed to be accurate and reliable. However, no responsibility is assumed by ICP DAS for its use, nor for any infringements of patents or other rights of third parties resulting from its use.

### Copyright

---

Copyright © 2012 by ICP DAS. All rights are reserved.

### Trademark

---

Names are used for identification only and may be registered trademarks of their respective companies.

# Tables of Contents

---

<b>1.</b>	<b>INTRODUCTION .....</b>	<b>4</b>
1.1	FEATURES .....	5
1.2	APPLICATIONS.....	5
1.3	SPECIFICATIONS .....	6
1.4	PCI DATA ACQUISITION FAMILY .....	7
1.5	PRODUCT CHECKLIST.....	8
<b>2.</b>	<b>HARDWARE CONFIGURATION .....</b>	<b>9</b>
2.1	BOARD LAYOUT.....	9
2.2	CONFIGURATION OF D/A OUTPUT SIGNAL .....	11
2.2.1	<i>The Configuration of Voltage Output .....</i>	<i>12</i>
2.2.2	<i>The Configuration of Current Sink .....</i>	<i>15</i>
2.3	CARD ID SWITCH.....	16
2.4	PIN ASSIGNMENT .....	17
2.5	SIGNAL CONNECTION.....	18
2.5.1	<i>Voltage Output Connection .....</i>	<i>18</i>
2.5.2	<i>Current Sink Connection .....</i>	<i>19</i>
2.5.3	<i>Current sink with internal power supply .....</i>	<i>19</i>
2.6	OUTPUT RANGE AND RESOLUTION.....	20
2.7	CALIBRATION.....	21
<b>3.</b>	<b>SOFTWARE INSTALLATION .....</b>	<b>23</b>
3.1	SOFTWARE INSTALLING PROCEDURE .....	23
3.2	PNP DRIVER INSTALLATION.....	24
3.3	CONFIRM THE SUCCESSFUL INSTALLATION.....	25
<b>4.</b>	<b>DEMO PROGRAMS.....</b>	<b>26</b>
4.1	DEMO PROGRAMS FOR WINDOWS .....	26
4.2	DEMO PROGRAMS FOR DOS .....	27
<b>5.</b>	<b>THE HARDWARE REGISTER .....</b>	<b>28</b>
5.1	HOW TO FIND THE I/O ADDRESS .....	28
5.2	THE I/O ADDRESS MAP.....	31
5.2.1	<i>RESET\ the Control Register.....</i>	<i>32</i>

5.2.2 AUX Control Register.....	32
5.2.3 AUX data Register.....	32
5.2.4 INT Mask Control Register.....	33
5.2.5 Aux Status Register.....	33
5.2.6 Interrupt Polarity Control Register.....	34
5.2.7 D/A Data Output.....	34
5.2.8 Jumper Status Register.....	35
5.2.9 Read Card ID Register.....	36

# 1. Introduction



The PISO-DA2U has 2 analog output channels with high-voltage isolation protection and provides universal PCI interface (3.3 V/5 V). The PISO-DA2U is fully compatible with the PISO-DA2, and users can replace the PISO-DA2 by the PISO-DA2U directly without software/driver modification.

The built-in high-quality isolation components on the PISO-DA2U make it featuring 3750 V<sub>DC</sub> bus-typed and channel-channel isolation, and offer durable abilities. For the PISO-DA2U, the voltage output ranges are +/-10 V, +/-5 V, 0~+10 V and 0~+5 V and the current output ranges are 0 ~ 20 mA and 4 ~ 20 mA. In addition, the PISO-DA2U also features the following advantages by ICP DAS's innovation:

1. Accurate and easy-to-use calibration:  
ICP DAS provides the software calibration instead of the manual calibration so that no jumpers and trim-pots are required anymore. The calibration data can be saved in the EEPROM for long-term use.
2. Channel to channel configuration:  
Each channel can be individually configured as voltage or current output with different output range.
3. Card ID:  
ICP DAS provides the card ID function for PISO-DA2U. Users can set a card ID for each card so that when more than two boards are used in a computer at the same moment, users can still instantly recognize them one by one.

## 1.1 Features

---

- Supports both +5 V and +3.3 V PCI bus for PISO-DA2U
- Supports +5 V PCI bus for PISO-DA2
- Two independent 12 bits analog output channels
- 3750 V<sub>DC</sub> bus and channels isolation protection
- 3000 V<sub>DC</sub> power isolation protection
- Analog output range
  - Voltage output
    - Bipolar:  $\pm 10$  V,  $\pm 5$  V
    - Unipolar: 0~10 V, 0~5 V
  - Current output
    - Current loop sink: 0~20 mA, 4~20 mA
- Software calibration
- Unipolar or bipolar output available from each converter
- Two pacer timer interrupt source
- Double buffered D/A latches
- The calibration data is fully stored in EEPROM

## 1.2 Applications

---

- Arbitrary waveform generation
- Control of Valves, switches, relays
- Programmable voltage sources
- Servo Control
- Programmable current sink

## 1.3 Specifications

Model Name	PISO-DA2	PISO-DA2U
<b>Analog Output</b>		
Isolation Voltage	3000 V (Bus Type, CH-to-CH)	
Channels	2	
Resolution	12-bit	
Accuracy	0.015% of FSR $\pm$ 1/2 LSB @ 25 °C, $\pm$ 10 V	
Output Range	Voltage: +/-10 V, +/-5 V, 0 ~ 10 V, 0 ~ 5 V Current: 0 ~ 20 mA, 4 ~ 20 mA	
Output Driving	+/- 5 mA	
Slew Rate	0.3 V/ $\mu$ s	
Output Impedance	0.1 $\Omega$ max.	
Operating Mode	Software	
<b>General</b>		
Bus Type	5 V PCI, 32-bit, 33 MHz	3.3 V/5 V Universal PCI, 32-bit, 33 MHz
Data Bus	8-bit	
Card ID	No	Yes (4-bit)
I/O Connector	Female DB9 x 2	
Dimensions (L x W x D)	170mm x 122mm x 22mm	189mm x 98mm x 22mm
Power Consumption	1350 mA @ +5 V	
Operating Temperature	0 ~ 60 °C	
Storage Temperature	-20 ~ 70 °C	
Humidity	5 ~ 85% RH, non-condensing	

### Optional Daughter Board

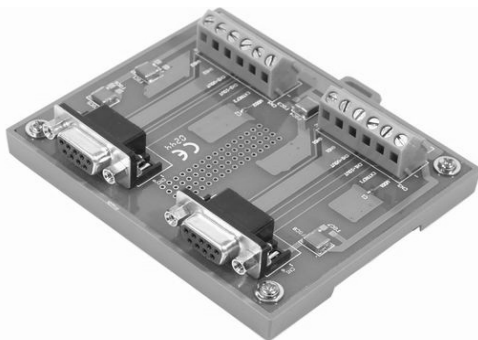

The DB-8425 Screw Terminal Board with 1.5 meter D-Sub 9-pin cables is provided for easy wire connection with the controlled device or equipment. The Daughter Board is not the standard component included in PISO-DA2/DA2U package.

## 1.4 PCI Data Acquisition Family

---

We provide a family of PCI-BUS data acquisition cards. These cards can be divided into three groups as follows:

- **PCI-series: high performance, isolated or non-isolated cards**
  - PCI-1002/1202/1800/1802/1602: multi-function family, non-isolated
  - PCI-P16R16/P16C16/P16POR16/P8R8: D/I/O family, isolated
  - PCI-TMC12: timer/counter card, non-isolated
  
- **PIO-series: cost-effective, non-isolated cards**
  - PIO-823/821: multi-function family
  - PIO-D168/D144/D96/D64/D56/D48/D24: D/I/O family
  - PIO-DA16/DA8/DA4: D/A family
  
- **PISO-series: cost-effective, isolated cards**
  - PISO-813: A/D card
  - PISO-P32C32/P64/C64: D/I/O family
  - PISO-P8R8/P8SSR8AC/P8SSR8DC: D/I/O family
  - PISO-730: D/I/O card
  - PISO-DA2: D/A card

## 1.5 Product Checklist

---

The shipping package includes the following items:

- One PISO-DA2/PISO-DA2U series card
- One CD-ROM
- One Quick Start Guide.

**It is recommended that you read the Quick Start Guide first.** All necessary and essential information is given in the Quick Start Guide, including:

- Where to get the software driver, demo programs and other resources.
- How to install the software.
- How to test the card.

### **Attention!**

**If any of these items are missing or damaged, contact the dealer from whom you purchased the product. Please save the shipping materials and carton in case you need to ship or store the product in the future.**



## 2. Hardware configuration

This section will describe the hardware setting of the PISO-DA2/DA2U. At first, the contents in the package and unpacking information that you should have are described. The jumper settings for the PISO-DA2/DA2U according to reference voltage sources, output voltage range and voltage or current output are also presented in the second stage.

### 2.1 Board Layout

#### ■ PISO-DA2's Layout

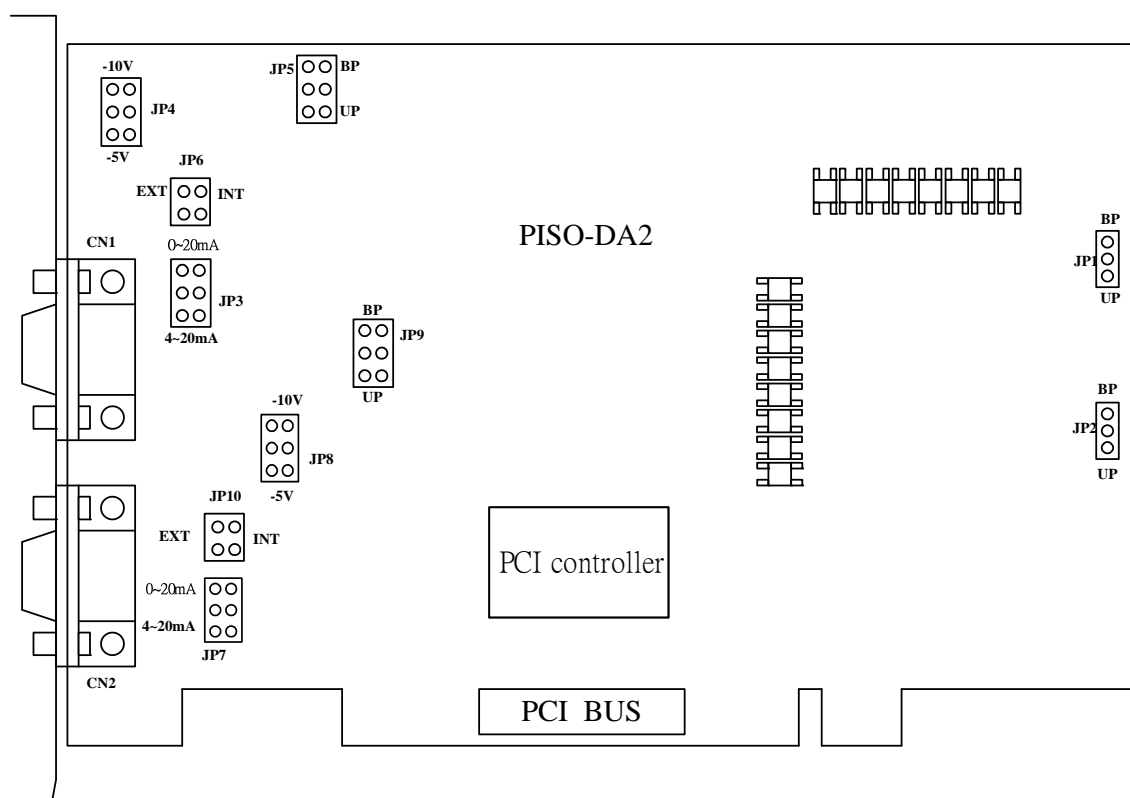

CN1	The terminal of D/A converter channel-1 for voltage or current output
CN2	The terminal of D/A converter channel-2 for voltage or current output
JP1/JP2/JP5/JP9	Bipolar or Unipolar setting
JP4/JP8	-5 V or -10 V internal reference voltage setting
JP3/JP7	0~20 mA or 4~20 mA current loop setting
JP6/JP10	External or internal reference voltage setting

## ■ PISO-DA2U's Layout

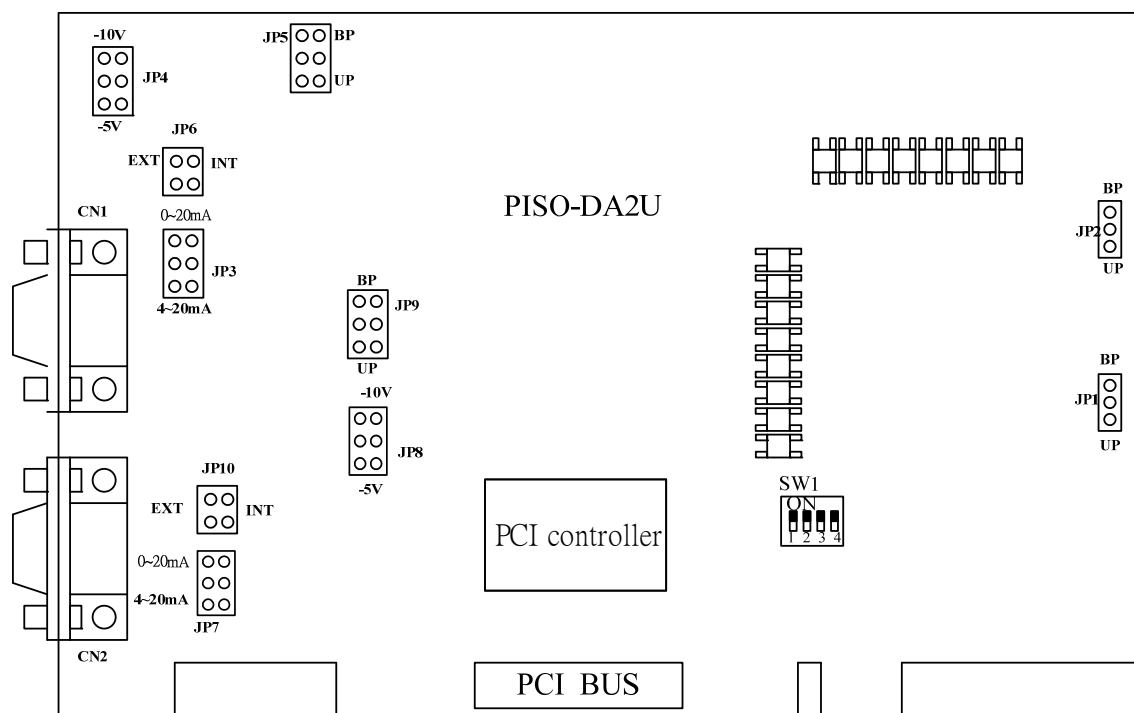

CN1	The terminal of D/A converter channel-1 for voltage or current output
CN2	The terminal of D/A converter channel-2 for voltage or current output
JP1/JP2/JP5/JP9	Bipolar or Unipolar setting
JP4/JP8	-5 V or -10 V internal reference voltage setting
JP3/JP7	0~20 mA or 4~20 mA current loop setting
JP6/JP10	External or internal reference voltage setting
SW1	Card ID function

## 2.2 Configuration of D/A Output Signal

The each D/A channel of PISO-DA2/DA2U can be independently configured as voltage or current output using different range to fit your application, as shown in Table 2-1 and Table 2-2. Generally, the range of voltage output, which includes bipolar and unipolar, is configured by jumper JP1, JP2, JP5, and JP9. In addition, the reference voltage and source are arranged by Jumper JP6 and JP10. JP4 and JP8 define the internal reference voltage source as -5 V or -10 V for channel 1 and 2 respectively.

For the current output, the user needs to define the reference voltage source as internal -5 V by jumper JP4 and JP8 and use jumper JP5 and JP9 to define signal as unipolar polarity. And then the range of the current output can be configured by jumper JP3 and JP7 for channel 1 and 2 respectively. **Note that each output channel can be set up as voltage or current output independently by using the corresponding setting jumper.** The more detail configuration method for the analog output will be demonstrated in the following section.

**Table 2-1: Jumper setting**

Output voltage	JP1, JP2, JP5, JP9	JP6, JP10, JP4, JP8
	Polarity selection	Ext/Int selection
-10 V ~ +10 V	Bipolar	Internal (-5 or -10 V)
-5 V ~ +5 V	Bipolar	Internal (-5 or -10 V)
0 V ~ 10 V	Unipolar	Internal (-5 or -10 V)
0 V ~ 5 V	Unipolar	Internal (-5 or -10 V)
(Ext_ref voltage)~ -(Ext_ref. voltage)	Bipolar	External
0~ - (Ext_ref. voltage)	Unipolar	External

**Table 2-2: Jumper setting for current sink**

Current sink	JP3, JP7	JP5, JP9	JP6, JP10 JP4, JP8
		Polarity selection	Ext/Int selection
0~20 mA	Output range setting	Unipolar	Internal (-5 or -10 V)
4~20 mA	Output range setting	Unipolar	Internal (-5 or -10 V)

## 2.2.1 The Configuration of Voltage Output

### Reference Source Setting (JP6/JP10/JP4/JP8)

The reference voltage source of PISO-DA2/DA2U's D/A converter can be provided by the internal generator or external reference voltage, which is coming from the connector CN1 and CN2. The setting of the reference sources for Channel 1 and Channel 2 are controlled by the jumper JP6 and JP10 respectively, as depicted in the following table2-3.

**Table 2-3: Setting reference source for channel 1 and 2.**

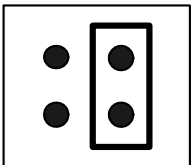
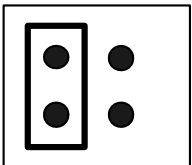
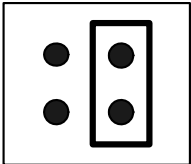
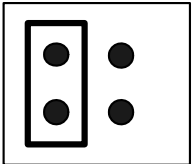
Channel	Internal Reference Voltage ( Default)	External Reference Voltage
Channel 1	<p>JP6</p>  <p>EXT INT</p>	<p>JP6</p>  <p>EXT INT</p>
Channel 2	<p>JP10</p>  <p>EXT INT</p>	<p>JP10</p>  <p>EXT INT</p>

If the internal reference voltage source is selected to implement the analog output of the D/A board, then the reference voltage level must be set as the internal voltage source -5 V or -10 V, which is precision voltage source provided by PISO-DA2/DA2U, by jumper JP4 (Channel 1) and JP8 (Channel 2). The detail setting method is illustrated as Table 2-4. The default setting is -5 V.

**Table 2-4: Internal Reference Voltage Setting**

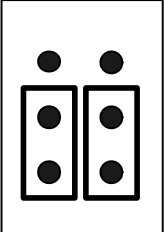
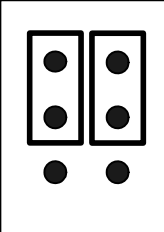
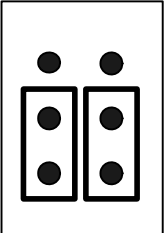
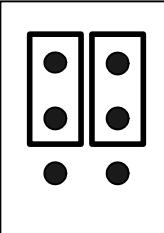
Channel	-5V ( Default)	-10V
Channel 1	<p>JP4</p>  <p>-10V</p> <p>-5V</p>	<p>JP4</p>  <p>-10V</p> <p>-5V</p>
Channel 2	<p>JP8</p>  <p>-10V</p> <p>-5V</p>	<p>JP8</p>  <p>-10V</p> <p>-5V</p>

## Output Range Setting (JP5/JP9)

After the configuration of reference voltage source, the practical voltage output range of PISO-DA2/DA2U can be regulated as either Bipolar or Unipolar by jumper JP5 and JP9. The detail setting is demonstrated in Table 2-5.

For example, if the jumper “JP4” and “JP5” are set as “-5 V” and “Unipolar” respectively, then the range of voltage output is 0~5 V for channel 1.

**Table 2.5: Output range setting**

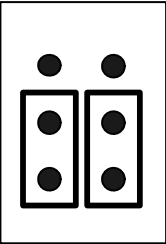
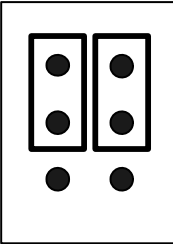
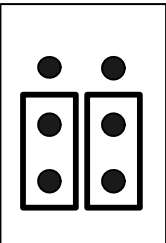
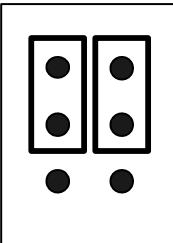
Channel	Unipolar ( Default)	Bipolar
Channel 1	<p>JP5</p>  <p>BP</p> <p>UP</p>	<p>JP5</p>  <p>BP</p> <p>UP</p>
Channel 2	<p>JP9</p>  <p>BP</p> <p>UP</p>	<p>JP9</p>  <p>BP</p> <p>UP</p>

## 2.2.2 The Configuration of Current Sink

### Output Range Setting (JP3/JP7)

If users want to apply PISO-DA2/DA2U to function as current output board, it provides the probability setting of current output mode using 0-20 mA or 4-20 mA loop current sink. In order to activate the current output, the PISO-DA2/DA2U board must be configured as the output voltage by the setting of **unipolar** and **internal reference voltage -5 V** for each output channel, in advance. Then Jumper JP3 and JP7 of PSIO-DA2/DA2U board can be utilized to select the current output range for channel 1 and 2 respectively. The detail setting is depicted as below Table 2-6.

**Table 2-6: Setting the output range of current sink.**

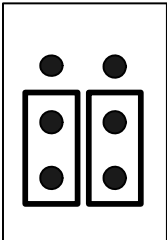
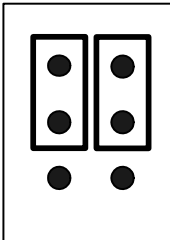
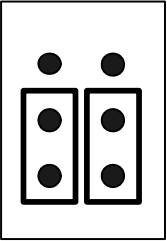
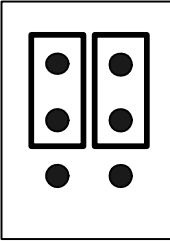
Channel	4-20mA ( Default)	0-20mA
Channel 1	<p>JP3</p>  <p>0-20mA</p> <p>4-20mA</p>	<p>JP3</p>  <p>0-20mA</p> <p>4-20mA</p>
Channel 2	<p>JP7</p>  <p>0-20mA</p> <p>4-20mA</p>	<p>JP7</p>  <p>0-20mA</p> <p>4-20mA</p>

## 2.3 Card ID Switch

The PISO-DA2U has a Card ID switch with which users can recognize the board by the ID via software when using two or more PISO-DA2U cards in one computer. The default Card ID is 0x0. For detail SW1 Card ID settings, please refer to Table 2-7.

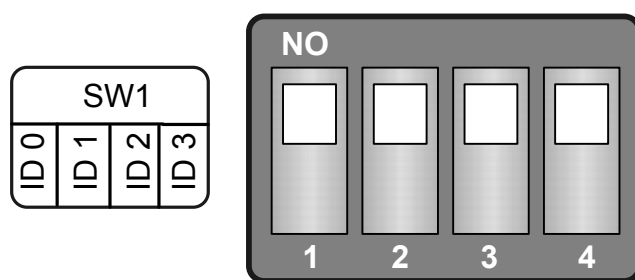

(Default Settings)

**Table 2-7: (\*) Default Settings; OFF → 1; ON → 0**

Card ID (Hex)	1 ID0	2 ID1	3 ID2	4 ID3
(*) 0x0	ON	ON	ON	ON
0x1	OFF	ON	ON	ON
0x2	ON	OFF	ON	ON
0x3	OFF	OFF	ON	ON
0x4	ON	ON	OFF	ON
0x5	OFF	ON	OFF	ON
0x6	ON	OFF	OFF	ON
0x7	OFF	OFF	OFF	ON
0x8	ON	ON	ON	OFF
0x9	OFF	ON	ON	OFF
0xA	ON	OFF	ON	OFF
0xB	OFF	OFF	ON	OFF
0xC	ON	ON	OFF	OFF
0xD	OFF	ON	OFF	OFF
0xE	ON	OFF	OFF	OFF
0xF	OFF	OFF	OFF	OFF



## 2.4 Pin Assignment

The PISO-DA2/DA2U is equipped with two sets of 9-pin D-type female connectors for wire connection of the output signal. CN1 and CN2 stand as are signal output connections of Channel 1 and CN2 respectively. The connector's pin assignment is specified as follows:

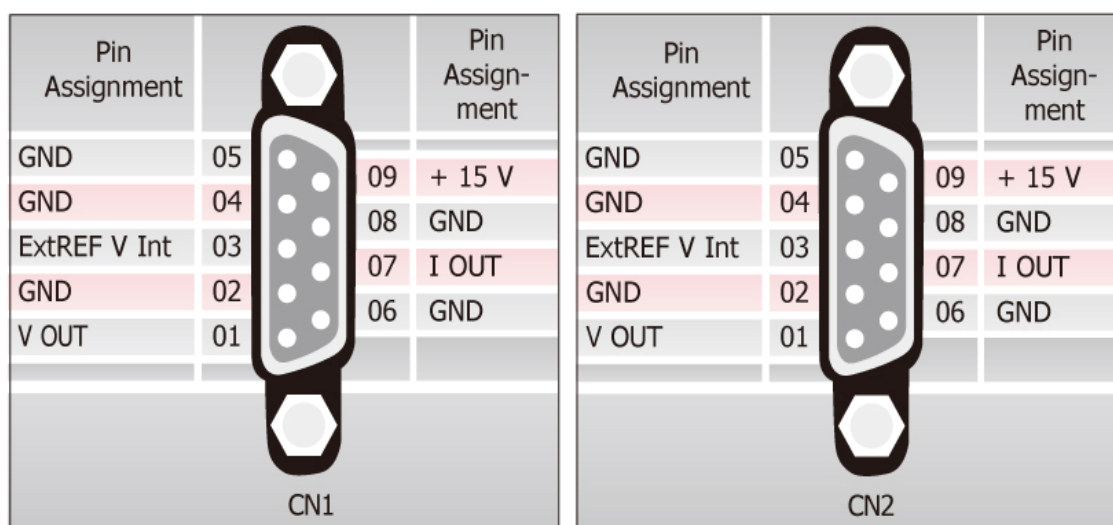

**Table 2-8: Pin assignment of CH1 and CH2**

CN1 pin assignment		CN2 pin assignment	
1	Voltage output	1	Voltage output
2	Signal GND	2	Signal GND
3	EXTREF: Ref. Voltage Input	3	EXTREF: Ref. Voltage Input
4	Signal GND	4	Signal GND
5	Signal GND	5	Signal GND
6	Signal GND	6	Signal GND
7	I <sub>OUT</sub> : Current output	7	I <sub>OUT</sub> : Current output
8	Signal GND	8	Signal GND
9	VDD:+15 V output	9	VDD:+15 V output

## 2.5 Signal Connection

---

This section will demonstrate the correct signal connection skill because it plays an important role for sending data accurately. According to the different applications, the wire connection may be different as shown in the following subsection. **Generally, when PISO-DA2/DA2U board is functioned as the voltage output application, the minimum load resistor must be bigger than 1 k $\Omega$ . However, when current output function of PISO-DA2/DA2U board is selected, then the maximum load resistor of the current loop sink has to be smaller than 400  $\Omega$ .**

### 2.5.1 Voltage Output Connection

Figure 2-1 presents the wire connection for voltage output from PISO-DA2/DA2U. It works fine when the external load resistor is bigger than 1 k $\Omega$ .

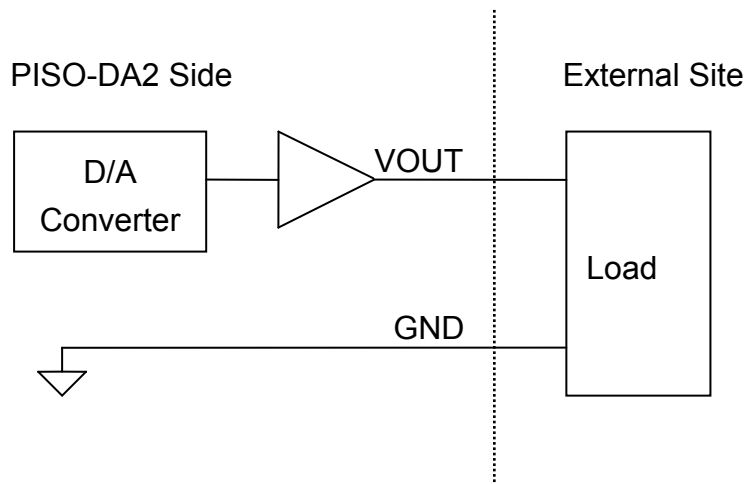

Figure 2-1: Voltage Output Connection

## 2.5.2 Current Sink Connection

Figure 2-2 depicts the wire connection for current output from PISO-DA2/DA2U when external power supply is used. It works fine when the external load resistor is smaller than **400  $\Omega$** . **Note that the external power supply used in this wire connection must be a DC source between +8 V and +36 V<sub>DC</sub>.**

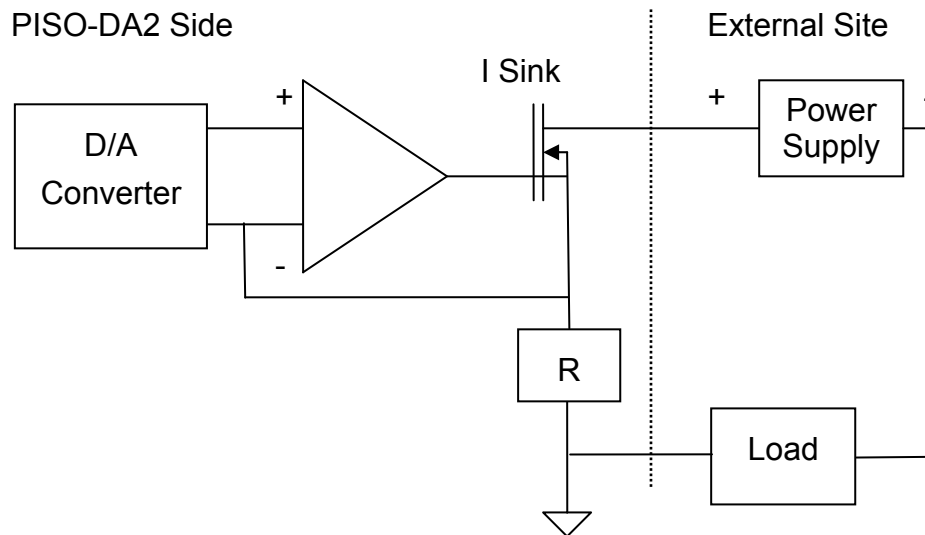

Figure 2-2: Current output Connection when external power is used

## 2.5.3 Current sink with internal power supply

If your system does not offer external power supply, a built-in +15 V<sub>DC</sub> power source provided by PISO-DA2/DA2U can be applied to build the signal current output in loop current sink type. The wire connection is illustrated as below.

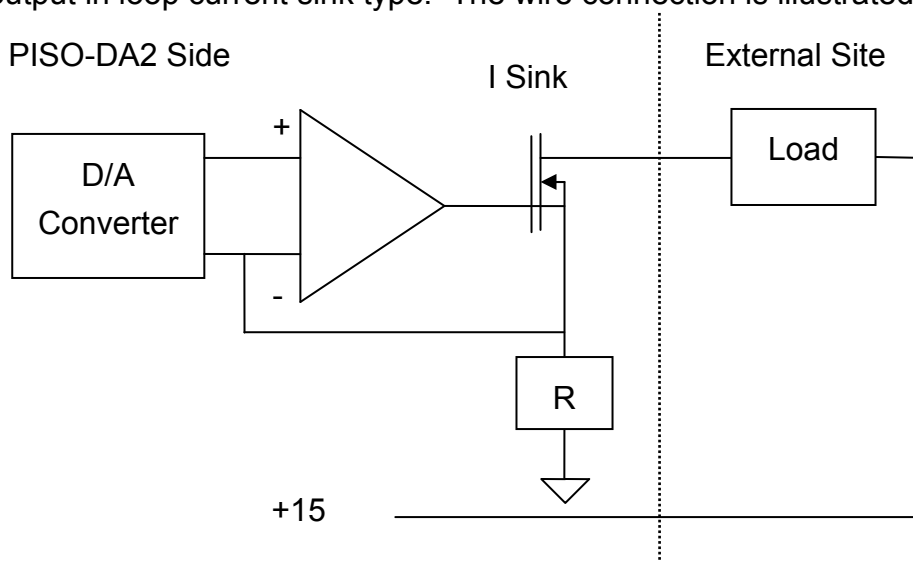

Figure 2-3: current output connection when internal power supply is used

## 2.6 Output Range and Resolution

The voltage and current output range of PISO-DA2/DA2U is represented as follow. The D/A converter is 12 bits. Based on the different output range, the resolution of every channel is figured out as Table 2-9.

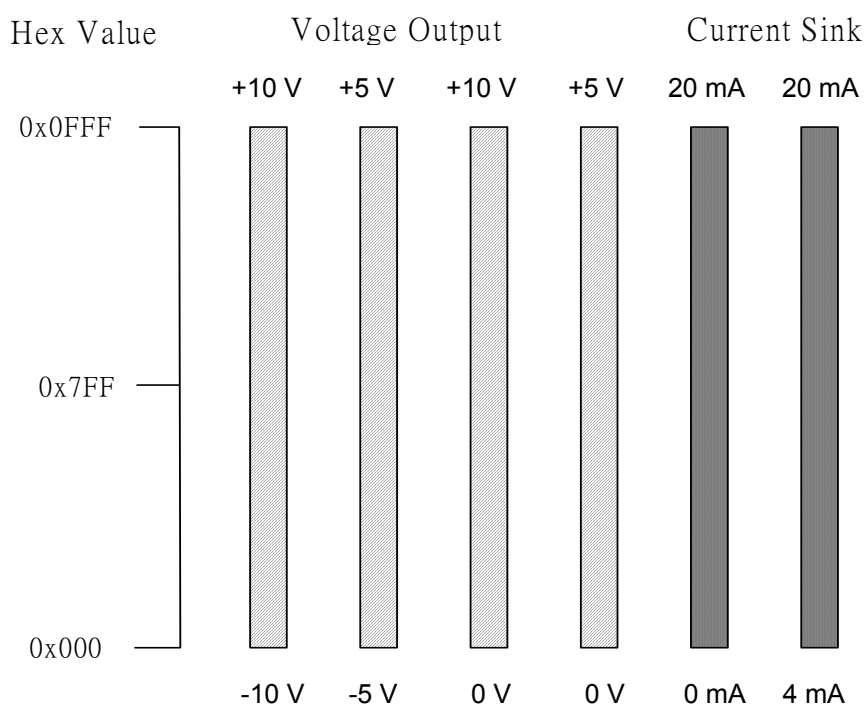

Figure 2-4: Output range and the corresponding revolution

Table 2-9: The resolution of each range

Configuration	Equivalent Bit	Resolution
-10 V ~ +10 V	12 bits	4.884 mV
-5 V ~ +5 V	12 bits	2.442 mV
0 ~ 10 V	12 bits	2.442 mV
0 ~ 5 V	12 bits	1.221 mV
0 mA ~ 20 mA	12 bits	4.884 $\mu$ A
4 mA~20 mA	12 bits	3.907 $\mu$ A

## 2.7 Calibration

The PISO-DA2/DA2U is shipped fully calibrated from the factory with calibration coefficients stored in the EEPROM on board. For more precise application of voltages or currents at the "system end", the following procedure provides a method that allows you to calibrate the board within your system, for correct voltages or currents at your field connection. This calibration allows the user to remove the effects of voltage drops caused by IR loss in the cable and connector.

At first, the user has to prepare two equipments for calibration: (1) precise multi-meter and power supply (External reference) for current calibration. Note that the calibrated values for analog output channel are stored to the address in the first 16 words of the EEPROM, as shown in Table 2-10.

**Table 2-10 Calibration values stored to the EEPROM address**

Output range	The address of the EEPROM for CH1	The address of the EEPROM for CH2
0~10 V	0	8
-10~10 V	1	9
0~5 V	2	10
-10~10 V	3	11
0 mA~20 mA	4 (minimum)	12(minimum)
	5(Maximum)	13(Maximum)
4 mA~20 mA	6(minimum)	14(minimum)
	7(Maximum)	15(Maximum)

After understanding the calibration mapping address and having precise multi-meter, the calibration procedure for each analog output channel is as the example for calibrating analog channel in 0~10 V setting and the calibration interface is shown in Figure 2-5.

Step 1: Please follow the jumper setting according to your analog output configuration.

Step 2: Run calibration tool, which is located in "/program files/DAQpro/PISO-DA2/calibration.exe", to open configuration interface, as shown in Figure 2-5.

Step 3: If we want to calibrate channel 1, for example, then let the calibration value set as 4095 and click “save” to save this value to the corresponding EEPROM.

Step 4: Click output button and then use precise multi-meter to measure the analog output.

Step 5: If the analog output is smaller or bigger than the allowance maximum value of analog output channel 1, then go to step 3~4 to change the saved value in EEPROM and output voltage value until the value is equal to the allowance maximum voltage output value.

Step 6: If the analog output is equal to the maximum allowance analog output, it means that the calibration process is finished for the setting range of analog output for channel 1. If user want to calibrate the other analog output range, please go to step 1~5 to proceed the individual calibration process.

Note that the maximum and minimum calibration process of the current output must be preceded if the user wants to calibrate the current output. And the procedure is the same the above.

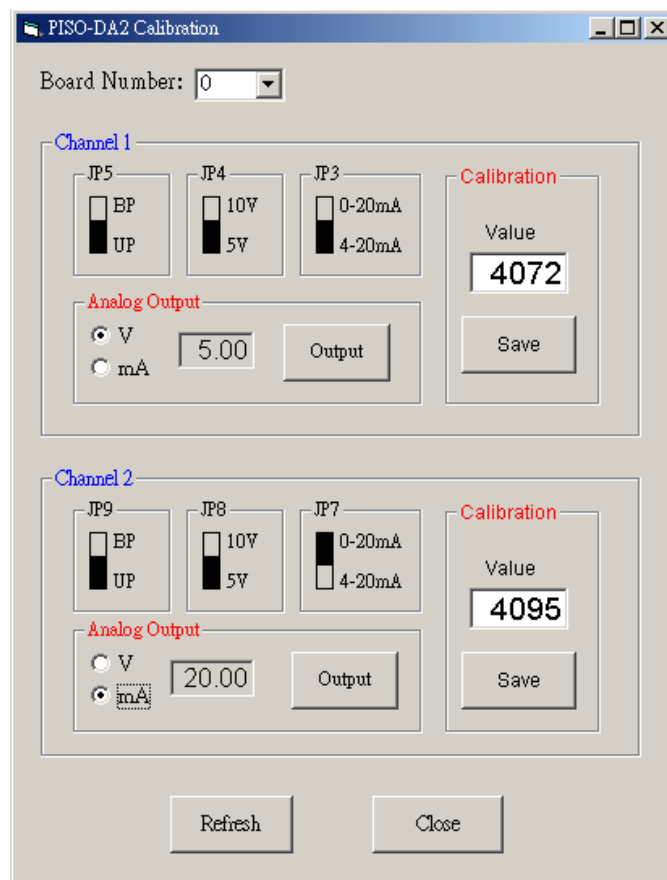

Figure 2-5: Calibration tool

## 3. Software Installation

The PISO-DA2/DA2U card can be used in DOS and Windows 98/ME/NT/2K and 32-bit/64-bit Windows XP/2003/Vista/7. The recommended installation procedure for windows is given in Sec. 3.1 ~ 3.3. Or refer to Quick Start Guide (CD:\NAPDOS\PCI\PISO-DA2\Manual\QuickStart\).

<http://ftp.icpdas.com/pub/cd/iocard/pci/napdos/pci/piso-da2/manual/quickstart/>

### 3.1 Software Installing Procedure

---

- UniDAQ SDK driver (32-bit/64-bit Windows XP/2003/Vista/7):

**Step 1:** Insert the companion CD into the CD-ROM drive and after a few seconds the installation program should start automatically. If it doesn't start automatically for some reason, double-click the **AUTO32.EXE** file in the **NAPDOS** folder on this CD.

**Step 2:** Click the item: "**PCI Bus DAQ Card**".

**Step 3:** Click the item: "**UniDAQ**".

**Step 4:** Click the item: "**DLL for Windows 2000 and XP/2003/Vista 32-bit**".

**Step 5:** Double-Click "**UniDAQ\_Win\_Setup\_x.x.x.x\_xxxx.exe**" file in the **Driver** folder.

- Windows driver (Windows 98/NT/2K and 32-bit Windows XP/2003/Vista/7):

**Step 1:** Insert the companion CD into the CD-ROM drive and after a few seconds the installation program should start automatically. If it doesn't start automatically for some reason, double-click the **AUTO32.EXE** file in the **NAPDOS** folder on this CD.

**Step 2:** Click the item: "**PCI Bus DAQ Card**".

**Step 3:** Click the item: "**PISO-DA2**".

**Step 4:** Click the item "**DLL for Windows 98/NT/2K and 32-bit Windows XP/2003/Vista/7**".

**Step 5:** Double-Click "**PISO\_DA2\_Win\_Setup\_vxxx.exe**" file in the **Driver** folder.

The setup program will then start the driver installation and copy the relevant files to the specified directory and register the driver on your computer. The directory where the drive is stoned is different for different windows versions, as shown below.

■ **Windows 64-bit Windows XP/2003/Vista/7:**

The UniDAQ.DLL file will be copied into the C:\WINNT\SYSTEM32 folder  
The NAPWNT.SYS and UniDAQ.SYS files will be copied into the  
**C:\Windows\SYSTEM32\DRIVERS folder**



For more detailed UniDAQ.DLL function information, please refer to UniDAQ SDK user manual (CD:\NAPDOS\PCI\UniDAQ\Manual\).  
<http://ftp.icpdas.com/pub/cd/iocard/pci/napdos/pci/unidaq/maunal/>

■ **Windows NT/2K and 32-bit Windows XP/2003/Vista/7:**

The PISODA.DLL file will be copied into the  
Windows NT/2000: **C:\WINNT\SYSTEM32 folder**  
Windows XP/2003/Vista/7: **C:\WINDOWS\SYSTEM32\DRIVERS**

■ **Windows 95/98/ME:**

The PISODA.DLL files will be copied into the  
**C:\WINDOWS\SYSTEM32\DRIVERS**



For more detailed PISODA.DLL function information, please refer to "PISO-DA2 Software Manual.pdf"  
(CD:\NAPDOS\PCI\PISO-DA2\Manual\).  
<http://ftp.icpdas.com/pub/cd/iocard/pci/napdos/pci/piso-da2/manual/>

## 3.2 PnP Driver Installation

---

After installing the hardware (PISO-DA2/DA2U) and power on your PC, Windows 98/Me/2K and 32-bit/64-bit Windows XP/2003/Vista/7 can find a PCI card device and ask user to provide a PISODA2.inf to install hardware driver on the computer. If user has trouble to precede this process, please refer to PnPinstall.pdf for more information.



### 3.3 Confirm the Successful Installation

---

Make sure the PISO-DA2/DA2U card installed is correct on the computer as follows:

**Step 1:** Select “**Start**” → “**Control Panel**” and then double click the “**System**” icon on Windows.

**Step 2:** Click the “**Hardware**” tab and then click the “**Device Manager**” button.

**Step 3:** Check the PISO-DA2/DA2U card which listed correctly or not, as illustrated below.

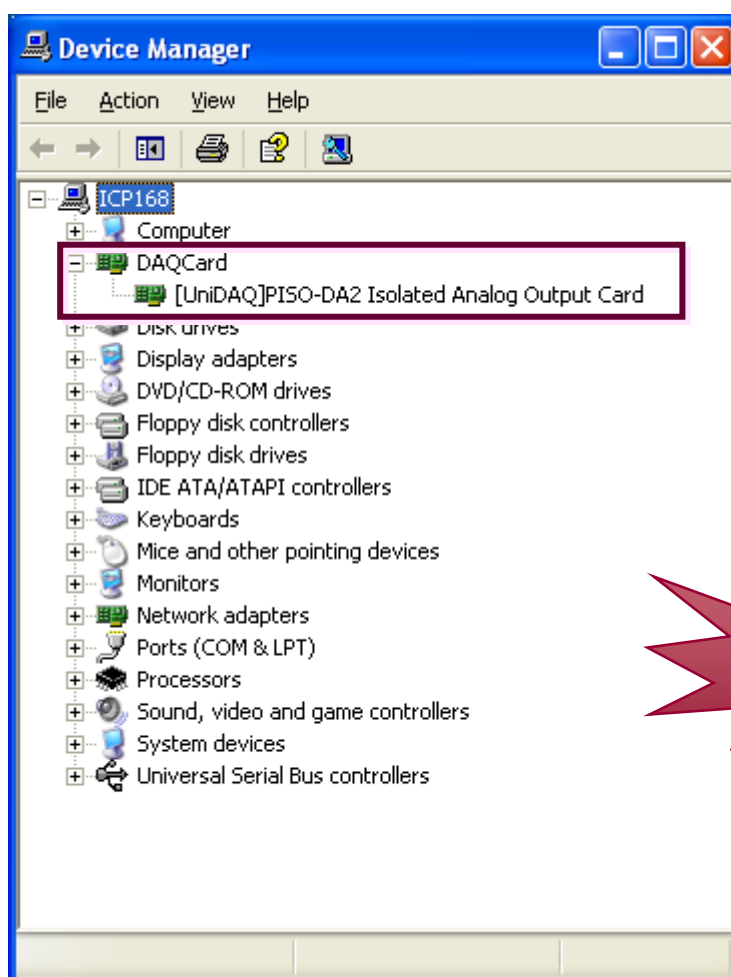

## 4. Demo Programs



### 4.1 Demo Programs for Windows

All of demo programs will not work normally if DLL driver (PISO-DA2 Classic Driver) would not be installed correctly. During the installation process of DLL driver (PISO-DA2 Classic Driver), the install-shields will register the correct kernel driver to the operation system and copy the DLL driver and demo programs to the correct position based on the driver software package you have selected (Windows 98/Me/NT/2000/XP/2003/Vista/7). After driver installation, the related demo programs and development library and declaration header files for different development environments are presented as follows.

The demo program is located at:

CD:\NAPDOS\PCI\PISO-DA2\DLL\Demo\

<http://ftp.icpdas.com/pub/cd/iocard/pci/napdos/pci/piso-da2/dll/demo/>

■ BCB 3 → For Borland C++ Builder 3  
PISODA.H → Header files  
PISODA.LIB → Linkage library for BCB

■ Delphi5 → For Delphi 5  
PISODA.PAS → Declaration files

■ VB6 → For Visual Basic 6  
PISODA.BAS → Declaration files

■ VB.NET2005 → For VB.NET2005  
PISODA.vb → Declaration files

■ CSharp2005 → For C#.NET2005  
PISODA.cs → Declaration files

#### A list of available demo programs is as follows:

- DEMO1: Get cards information
- DEMO2: D/A output
- DEMO3: Read/Write from/to EEPROM and software calibration.
- DEMO4: Two cards D/A output

The detailed demo information of Windows refers to PISO-DA2 software manual (CD:\NAPDOS\PCI\PISO-DA2\Manual\).

<http://ftp.icpdas.com/pub/cd/iocard/pci/napdos/pci/piso-da2/manual/>

## 4.2 Demo Programs for DOS

---

The related DOS software and demos are located on the CD as below:

CD:\NAPDOS\PCI\PISO-DA2\dos\pisoda2\

<http://ftp.icpdas.com/pub/cd/iocard/pci/napdos/pci/piso-da2/dos/pisoda2/>

After installing the software, the following drivers will be installed onto your hard disk:

- \TC\\*. \* → for Turbo C 2.xx or above
- \MSC\\*. \* → for MSC 5.xx or above
- \BC\\*. \* → for BC 3.xx or above

- \TC\LIB\\*. \* → for TC library
- \TC\DEMO\\*. \* → for TC demo program
- \TC\DIAG\\*. \* → for TC diagnostic program

- \TC\LIB\Large\\*. \* → TC large model library
- \TC\LIB\Huge\\*. \* → TC huge model library
- \TC\LIB\Large\PIO.H → TC declaration file
- \TC\LIB\Large\TCPIO\_L.LIB → TC large model library file
- \TC\LIB\Huge\PIO.H → TC declaration file
- \TC\LIB\Huge\TCPIO\_H.LIB → TC huge model library file

- \MSC\LIB\Large\PIO.H → MSC declaration file
- \MSC\LIB\Large\MSCPIO\_L.LIB → MSC large model library file
- \MSC\LIB\Huge\PIO.H → MSC declaration file
- \MSC\LIB\Huge\MSCPIO\_H.LIB → MSC huge model library file

- \BC\LIB\Large\PIO.H → BC declaration file
- \BC\LIB\Large\BCPIO\_L.LIB → BC large model library file
- \BC\LIB\Huge\PIO.H → BC declaration file
- \BC\LIB\Huge\BCPIO\_H.LIB → BC huge model library file

For every development environments, it fully includes the following demo programs.

DEMO1: INT\_CHAN\_0 & INT\_CHAN\_1 timer interrupt demo  
DEMO2: D/A Output  
DEMO3: Write the data to EEPROM  
DEMO4: Read data from EEPROM.  
DEMO5: Software calibration

## 5. The Hardware Register

The detailed descriptions of the registers format for PISO-DA2/DA2U will be presented here for advance user. This information is quite useful for the programmers who hope to handle the card by themselves. However we suggest that user need to understand the hardware system more clearly before starting to design the program for controlling it by them. The following section will help users to understand the registers system of the PISO-DA2/DA2U.

### 5.1 How to Find the I/O Address

---

The Plug & Play BIOS will assign an appropriate I/O address for each PIO/PISO series card during the power-on stage. The fixed IDs for the PIO/PISO series cards are shown in the tables below:

	PISO-DA2	PISO-DA2/PISO-DA2U	
	Tiger 100	Tiger 320	
Vendor ID	0xE159	0xE159	0xE159
Device ID	0x0002	0x0001	0x0001
Sub-vendor ID	0x80	0x0280	0x4280
Sub-device ID	0x0B	0x03	0x03
Sub-aux ID	0x00	0x00	0x00

The utility program under Windows operation system, **PIO\_PISO.EXE**, can detect and display all the hardware information of PIO/PISO cards installed in the PC. It is very useful for understanding hardware information of all PIO/PISO series card. After executing the utility, the detail information for all PIO/PISO cards installed in the PC can be demonstrated as follows. The detail definition of the hardware system for PIO/PISO PCI interface board is represented in Table 5-1.

## PIO\_PISO.EXE for Windows

The PIO\_PISO.exe utility is located on the CD as below and is useful for all PIO/PISO series cards.

CD:\NAPDOS\PCI\Utility\Win32\PIO\_PISO\

[http://ftp.icpdas.com/pub/cd/iocard/pci/napdos/pci/utility/win32/pio\\_piso/](http://ftp.icpdas.com/pub/cd/iocard/pci/napdos/pci/utility/win32/pio_piso/)

After executing the utility, detailed information for all PIO/PISO cards that are installed in the PC will be shown, as illustrated below:

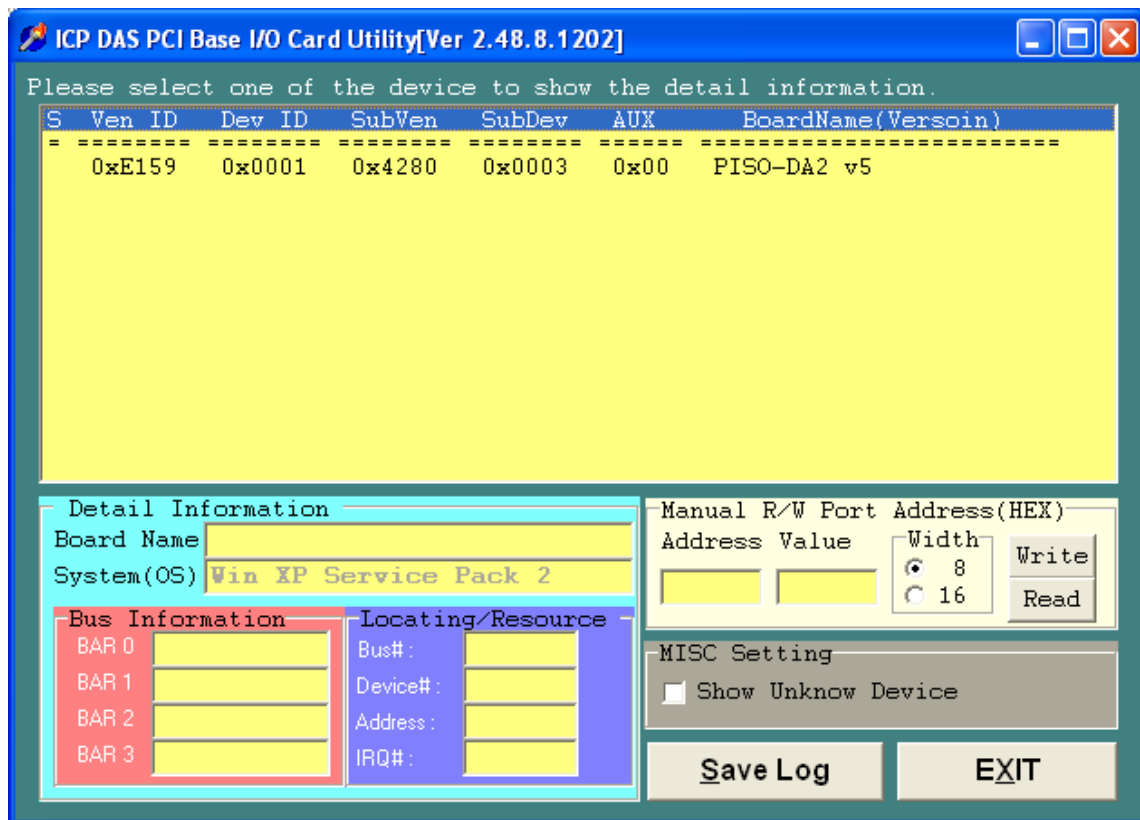

Figure 5-1: PIO\_PISO.EXE

**Note:** The PIO\_PISO.EXE application is valid for all PIO/PISO cards. The user can execute the PIO\_PISO.EXE file to retrieve the following information:

- List all PIO/PISO cards installed in the PC
- List the resources allocated to each PIO/PISO card
- List the wSlotBus and wSlotDevice details for identification of specific PIO/PISO cards. (Refer to Sec. 5.1 for more information)

**Table 5-1: Hardware information of PCI bus for PIO/PISO series card**

PIO/PISO series card	Description	Sub_vendor	Sub_device	Sub_AUX
PIO-D144	144 * D/I/O	80	01	00
PIO-D96	96 * D/I/O	80	01	10
PIO-D64	64 * D/I/O	80	01	20
PIO-D56	24* D/I/O +	80	01	40
PIO-D48	48*D/I/O	80	01	30
PIO-D24	24*D/I/O	80	01	40
PIO-823	Multi-function	80	03	00
PIO-821	Multi-function	80	03	10
PIO-DA16	16*D/A	80	04	00
PIO-DA8	8*D/A	80	04	00
PIO-DA4	4*D/A	80	04	00
PISO-C64	64 * isolated D/O	80	08	00
PISO-P64	64 * isolated D/I	80	08	10
PISO-P32C32	32 + 32	80	08	20
PISO-P8R8	8* isolated D/I +	80	08	30
PISO-P8SSR8DC	8* isolated D/I +	80	08	30
PISO-730	16*DI+16*D/O +	80	08	40
PISO-813	32 * isolated A/D	80	0A	00
<b>PISO-DA2</b>	<b>2 * isolated D/A</b>	<b>80</b>	<b>0B</b>	<b>00</b>

## 5.2 The I/O Address Map

The I/O address of PIO/PISO series card is automatically assigned by the main board ROM BIOS. The I/O address can also be re-assigned by user. It is strongly recommended that users themselves do not change the I/O address. The plug & play BIOS of the PCI-board will automatically assign the proper I/O address to each PIO/PISO series card very well. The I/O addresses of the PISO-DA2/DA2U are given as follows, which is based on the base address **wBase**.

**Table 5-2 : I/O address of the PISO-DA2/DA2U where wBase.**

Address	Read	Write
wBase+0x0	RESET control register	RESET control register
wBase+0x2	AUX control register	AUX control register
wBase+0x3	AUX data register	AUX data register
wBase+0x5	INT mask control register	INT mask control register
wBase+0x7	AUX pin status register	AUX pin status register
wBase+0x2a	INT polarity control register	INT polarity control register
wBase+0xc0	Not used	Write to the high byte of D/A
wBase+0xc4	Not used	Write to the low byte of D/A
wBase+0xc8	Not used	Write to the high byte of D/A
wBase+0xcc	Not used	Write to the low byte of D/A
wBase+0xd0	Read from 8254-counter0	Write to 8254-counter0
wBase+0xd4	Read from 8254-counter1	Write to 8254-counter1
wBase+0xd8	Read from 8254-counter2	Write to 8254-counter2
wBase+0xdc	Read from 8254 control word	Write to 8254 control word
wBase+0xe0	Read in Jumper status	Not used
wBase+0xf0	Read the Card ID	Not used

**Note: Refer to Sec. 5.1 for more information regarding wBase.**

---

## 5.2.1 RESET\ the Control Register

When the PC is first power-up, the RESET\ signal is in Low-state. **This will disable all D/A operations.** The user has to set the RESET\ signal to High-state before using any D/A command. Note that **wBase** is the base address of PISO-DA2/DA2U board mapping from your PC.

**Table 5-3: Read/Write control Register**

(Read/Write): wBase+0

Bit 7	Bit 6	Bit 5	Bit 4	Bit 3	Bit 2	Bit 1	Bit 0
Reserved	Reserved	Reserved	Reserved	Reserved	Reserved	Reserved	RESET\

---

## 5.2.2 AUX Control Register

This register is designed for feature extension and for enable or disable of the reading/writing data from or to the EEPROM. And it is reversed for internal utilization and do not apply this control register under any consideration.

**Table 5-4: Aux Control Register**

(Read/Write): wBase+2

Bit 7	Bit 6	Bit 5	Bit 4	Bit 3	Bit 2	Bit 1	Bit 0
Aux7	Aux6	Aux5	Aux4	Aux3	Aux2	Aux1	Aux0

---

## 5.2.3 AUX data Register

This register controls the read/write function of the EEPROM on board. There are all reversed by ICPDAS internal use. If the user wants to access this EEPROM, please refer to function read/write of the EEPROM provided by the driver toolkit.

**Table 5-5: Aux data Register**

(Read/Write): wBase +3

Bit 7	Bit 6	Bit 5	Bit 4	Bit 3	Bit 2	Bit 1	Bit 0
Aux7	Aux6	Aux5	Aux4	Aux3	Aux2	Aux1	Aux0



---

## 5.2.4 INT Mask Control Register

The INT mask control register is presented as following table. The detail function for these control register is described as below.

**Table 5-6: INT mask control Register**

(Read/Write): wBase+5

Bit 7	Bit 6	Bit 5	Bit 4	Bit 3	Bit 2	Bit 1	Bit 0
0	0	0	0	0	0	EN1	EN0

EN0=0→ disable INTO to be an interrupt signal (default)

EN0=1→ enable INTO to be an interrupt signal

EN1=0→ disable INT1 to be an interrupt signa (default)

EN1=1→ enable INT1 to be an interrupt signal

The following is the partial programs for DOS C development environment enable or disable interrupt function. For more information, please refer to the DOS demo program demo1.c .

```
outportb(wBase+5,0); // disable all interrupts
outportb(wBase+5,1); // enable interrupt of INTO
outportb(wBase+5,2); // enable interrupt of INT1
outportb(wBase+5,3); // enable all two channels of interrupt
```

---

## 5.2.5 Aux Status Register

Based on the auxiliary status register, Aux0 (bit 0) and Aux 1(bit 1) stand as INTO and INT1 signal respectively. Aux2~3 (bit 2~3) represents the control register of the EEPROM and Aux4~7 (bit 4~7) depicts the Aux-ID. Generally, the Aux 0~1 are used as interrupt sources. Interrupt service has to check this register to start service routing.

**Table 5-7: AUX Status Register**

(Read/Write): wBase+7

Bit 7	Bit 6	Bit 5	Bit 4	Bit 3	Bit 2	Bit 1	Bit 0
Aux7	Aux6	Aux5	Aux4	Aux3	Aux2	Aux1	Aux0

---

## 5.2.6 Interrupt Polarity Control Register

The interrupt polarity control register is presented as following table. It is used to invert the interrupt signal or not. The detail function for these control register is described as below.

**Table 5-8: Interrupt polarity control Register**

(Read/Write): wBase+0x2A

Bit 7	Bit 6	Bit 5	Bit 4	Bit 3	Bit 2	Bit 1	Bit 0
0	0	0	0	×	×	INV1	INV0

- INV0=0→ invert signal from INTO;
- INV0=1→ do not invert signal from INTO;
- INV1=0→ invert signal from INT1;
- INV1=1→ do not invert signal from INTO;

The following is the partial programs for DOS C development environment enable or disable inverting function for interrupt signal.

```
outputb(wBase+0x2a,0); /* select the inverted input from all 2 channels*/
outputb(wBase+0x2a,3); /*select the non-inverted input from all 2 channels */

outputb(wBase+0x2a,2); /* select the inverted input of INTO */
/* select the non-inverted input from the others */
```

---

## 5.2.7 D/A Data Output

Table 5-9 and 5-10 is the output data buffer for D/A channel-1 and Table 5-11 and 5-12 is the output data buffer for D/A channel-2. These registers are write only and user can use these to output the data through analog output CH1 and CH2.

**Table 5-9: high byte of D/A channel-1**

(Write): wBase+0xc0

Bit 7	Bit 6	Bit 5	Bit 4	Bit 3	Bit 2	Bit 1	Bit 0
0	0	0	0	D11	D10	D9	D8

**Table 5-10: Low byte of D/A channel-1**

(Write): wBase+0xc4

Bit 7	Bit 6	Bit 5	Bit 4	Bit 3	Bit 2	Bit 1	Bit 0
D7	D6	D5	D4	D3	D2	D1	D0

**Table 5-11: high byte of D/A channel-2**

(Write): wBase+0xc8

Bit 7	Bit 6	Bit 5	Bit 4	Bit 3	Bit 2	Bit 1	Bit 0
0	0	0	0	D11	D10	D9	D8

**Table 5-12: Low byte of D/A channel-2**

(Write): wBase+0xcc

Bit 7	Bit 6	Bit 5	Bit 4	Bit 3	Bit 2	Bit 1	Bit 0
D7	D6	D5	D4	D3	D2	D1	D0

---

## 5.2.8 Jumper Status Register

This register shows the status of Hardware jumper setting. About the detail information, please refer to the following description.

**Table 5-13: Jumper status register**

(Read): wBase+0xe0

Bit 7	Bit 6	Bit 5	Bit 4	Bit 3	Bit 2	Bit 1	Bit 0
X	x	JP9	JP8	JP7	JP5	JP4	JP3

JP3=0 → JP3 is set at 0-20 mA for the current output of channel 1.

JP3=1 → JP3 is set at 4-20 mA for the current output of channel 1

JP4 =0 → JP4 is set at -10 V for internal reference voltage source of channel 1.

JP4 =1 → JP4 is set at -5 V for internal reference voltage source of channel 1.

JP5=0 → JP5 is set at Bipolar for channel 1

JP5=1 → JP5 is set at Unipolar for channel 1

JP7=0 → JP7 is set at 0-20 mA for the current output of channel 2

JP7=1 → JP7 is set at 4-20 mA for the current output of channel 2

JP8 =0 → JP8 is set at -10 V for internal reference voltage source of channel 2

JP8 =1 → JP8 is set at -5 V for internal reference voltage source of channel 2

JP9=0 → JP9 is set at Bipolar for channel 2

JP9=1 → JP9 is set at Unipolar for channel 2

---

## 5.2.9 Read Card ID Register

The Card ID can be set using the SW1 dip switch (refer to [Sec. 2.3](#) Card ID Switch), so it is easy to set the correct connections between cards and devices. So, by reading the Card ID users can check whether their program is accessing the correct card. About the detail information for Card ID register, please refer to the following description.

**Table 5-14: Read Card ID register**

(Read): wBase+0xf0

Bit 7	Bit 6	Bit 5	Bit 4	Bit 3	Bit 2	Bit 1	Bit 0
X	X	X	X	ID3	ID2	ID1	ID0

```
wCardID = inportb(wBase+0xf0) & 0xF;      /* Read Card ID*/
```



**Note: The Card ID function is only supported by the PISO-DA2U.**